

# Artificial Intelligence Based MPPT Techniques for Solar Power System: A review

Kah Yung Yap, Charles R. Sarimuthu, and Joanne Mun-Yee Lim

**Abstract**—In the last decade, artificial intelligence (AI) techniques have been extensively used for maximum power point tracking (MPPT) in the solar power system. This is because conventional MPPT techniques are incapable of tracking the global maximum power point (GMPP) under partial shading condition (PSC). The output curve of the power versus voltage for a solar panel has only one GMPP and multiple local maximum power points (MPPs). The integration of AI in MPPT is crucial to guarantee the tracking of GMPP while increasing the overall efficiency and performance of MPPT. The selection of AI-based MPPT techniques is complicated because each technique has its own merits and demerits. In general, all of the AI-based MPPT techniques exhibit fast convergence speed, less steady-state oscillation and high efficiency, compared with the conventional MPPT techniques. However, the AI-based MPPT techniques are computationally intensive and costly to realize. Overall, the hybrid MPPT is favorable in terms of the balance between performance and complexity, and it combines the advantages of conventional and AI-based MPPT techniques. In this paper, a detailed comparison of classification and performance between 6 major AI-based MPPT techniques have been made based on the review and MATLAB/Simulink simulation results. The merits, open issues and technical implementations of AI-based MPPT techniques are evaluated. We intend to provide new insights into the choice of optimal AI-based MPPT techniques.

**Index Terms**—Maximum power point tracking (MPPT), artificial intelligence (AI), fuzzy logic control (FLC), artificial neural network (ANN), genetic algorithm (GA), swarm intelligence (SI), machine learning (ML).

## I. INTRODUCTION

THE solar power system is widely used nowadays due to its cost-effectiveness and high efficiency [1]. It is considered as one of the most promising renewable energy source (RES) because of its cleanliness, abundance and environmental friendliness, compared with conventional energy sources such as oil, natural gas and fossil fuel [2]. Despite its advantages, the output active power  $P$  from solar power system varies according to the solar irradiance  $E_e$  and opera-

tion temperature  $T$ , especially under rapid changing partial shading condition (PSC) due to the non-linear characteristic of photovoltaic (PV) cell [3]. The complex relationship between power output with PV input parameters results in unsatisfactory power extraction [4]. To alleviate the aforementioned limitation, maximum power point tracking (MPPT) becomes the research focus to improve the efficiency  $\eta$  of the solar power system and ensure that the operation point is always at maximum power point (MPP) [5]. The peak uniform conditions without PSC can be tracked effectively by using conventional hill-climbing (HC) MPPT techniques such as perturb and observe (P&O) and incremental conductance (IC) [6]. However, the power output from solar power system generates multiple peaks under PSC, including one global MPP (GMPP) and many other local peaks as illustrated in Fig. 1, which complicates the HC MPPT technique to search for the real maximum [7]. Hence, MPPT evolves into an algorithm based on evolutionary, heuristic and meta-heuristic techniques. It is designated to track global peak instead of local peaks since conventional HC MPPT techniques fail to track global peak under PSC and rapid changing of solar irradiance [8].

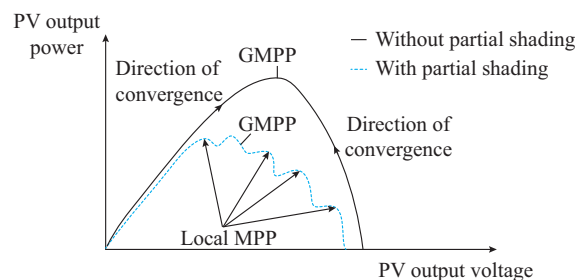

Fig. 1. Curve of power versus voltage for a solar panel under PSC.

Apart from electronically implemented MPPTs, there are other techniques to improve solar energy efficiency such as integrated soft-computing weather forecast and adjustment of the tilting angle of solar panel to track the sun direction [9]. We only focus on the artificial intelligence (AI)-based MPPT techniques for DC-DC converter in the solar power system. The integration of various AI optimization techniques with MPPT is aimed to resolve and rectify the following limitations of a conventional HC MPPT:

- 1) Lack of adaptive, robust and self-learning capabilities.
- 2) High steady-state error, power oscillation at MPP and slow transient response.

Manuscript received: July 23, 2019; accepted: April 1, 2020. Date of Cross-Check: April 1, 2020. Date of online publication: November 26, 2020.

This work was supported by the School of Engineering, Monash University Malaysia.

This article is distributed under the terms of the Creative Commons Attribution 4.0 International License (<http://creativecommons.org/licenses/by/4.0/>).

K. Y. Yap, C. R. Sarimuthu (corresponding author), and J. M.-Y. Lim are with the Department of Electrical and Computer Systems Engineering (ECSE), School of Engineering, Monash University, Subang Jaya, Malaysia (e-mail: kah.yap@monash.edu; Charles.Raymond.Sarimuthu@monash.edu; joanne.lim@monash.edu).

DOI: 10.35833/MPCE.2020.000159

3) Inability to find GMPP, trapping at local MPP and incorrect perturbation direction under PSC or sudden irradiance change due to MPPT failure [10].

In general, the existing AI-based MPPT techniques utilize the sensory information including solar irradiance  $E_e$ , input voltage of solar power system  $V_{L,PV}$  and input current  $I_{L,PV}$  measurements to predict and estimate the GMPP throughout the non-linear  $P$ - $V$  curve. The integration of AI in MPPT accelerates the convergence speed and transient response because of their complex, robust, self-learning and digitalised system. MPPT techniques are categorized into two major groups: conventional HC MPPT and AI-based MPPT [11]. AI-based MPPT term is known as computational intelligence (CI) based MPPT, soft-computing MPPT, modern MPPT or bio-inspired MPPT. It mainly consists of fuzzy logic control (FLC), artificial neural network (ANN), differential evolution (DE), genetic algorithm (GA), particle swarm optimization (PSO), Tabu search (TS), Cuckoo search (CS), firefly algorithm (FA) and hybrid algorithms. Conventional HC MPPT techniques consist of P&O, IC, HC, constant voltage, fractional short-circuit current, fractional open-circuit voltage, scanning-tracking of current-voltage ( $I$ - $V$ ) curve, Fibonacci searching, global MPPT (GMPPT) segmentation searching and extremum seeking control. There are various sources of comparative literature review for all types of MPPT. Existing literature only covers AI-based and hybrid MPPT techniques. There are very limited comparative studies, specifically in AI-based MPPT techniques [11]-[13].

The contributions of this paper are as follows: ① the applicability and utilizations of AI in MPPT for solar power system are reviewed; ② current development and research areas of AI in MPPT are overviewed; ③ comparative analysis and performance evaluation of each AI algorithm in MPPT techniques are provided. In this paper, popular AI-based MPPT techniques are compared and evaluated. This paper provides a comprehensive insight into the latest development and advancement of AI, which is applied in MPPT for the solar power system. In general, all conventional MPPT techniques exhibit the common disadvantages, including power fluctuation, inability to operate normally under PSC and rapid irradiance changes, trapping at one of the local MPPs and oscillation around MPP [14], [15]. Hence, AI is adopted to overcome these drawbacks [16], [17]. A typical MPPT block diagram is shown in Fig. 2, where PWM stands for pulse width modulation.

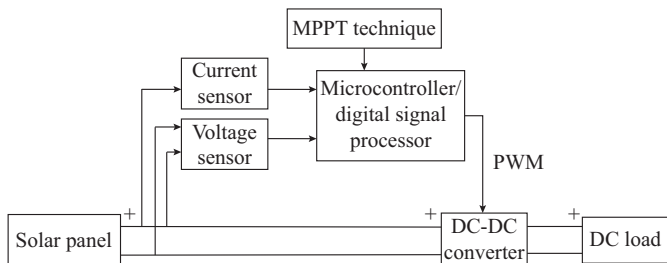

Fig. 2. Block diagram of typical MPPT.

The design of a conventional control (CC) system involves mathematical modelling, which consists of all the dynamics of the plant and is known as the mathematicians' approach since the designer must model the plant mathematically before it is to be controlled. In contrast, to develop an IC system, the system behavior is necessary for the inputs and the IC system is responsible for autonomous and abstract modelling [18].

## II. REVIEW OF AI-BASED MPPT TECHNIQUES

### A. FLC

FLC is a control system based on fuzzy logic which converts analogue inputs into continuous digital values of 0 and 1 [19]. It is invented to resolve the limitations of conventional MPPT techniques which include the oscillation around MPP, high settling time and steady-state error (SSE). It is easy to design because it does not require the knowledge of an accurate model of MPPT. Hence, FLC is popular in the last decade [20]. FLC can be integrated with HC algorithm such as P&O and IC [21]. FLC translates HC algorithm into fuzzy rules [22]. It has been proven to provide higher power efficiency when there is irradiance change and load current compared with HC algorithm [23].

$$\frac{dP_{PV}}{dV_{PV}} = E_{rr} = \frac{P_{PV}(k) - P_{PV}(k-1)}{V_{PV}(k) - V_{PV}(k-1)} \quad (1)$$

$$\Delta \frac{dP_{PV}}{dV_{PV}} = \Delta E_{rr} = E_{rr}(k) - E_{rr}(k-1) \quad (2)$$

where  $E_{rr}$  is the number of error;  $\Delta P$  is the ratio of change of power;  $\Delta V$  is the change of voltage;  $\Delta E_{rr}$  is the rate of change of error; and  $P_{PV}$  and  $V_{PV}$  are the output active power and voltage of PV panels, respectively. A fuzzy controller can be implemented on any low to medium powerful microcontroller including Arduino Mega and Microchip to manipulate the output duty cycle  $D$  of the DC-DC converter depending on  $T$  and  $E_e$ , which searches the MPP of the solar power system [24]. The solar power is dependent on the dynamic of solar irradiance [25]. Additionally, FLC is reconfigurable and highly flexible because it can be reprogrammable through a field-programmable gate array (FPGA) [26]. FLC is a relatively simpler, cost-effective and historically older implementation of CI in MPPT. The general rules of FLC on MPPT are shown as follows, where  $\Delta V$  is the change of voltage; and  $\Delta P$  is the change of active power.

- 1) If  $\Delta P > 0$  and  $\Delta V > 0$ ,  $\Delta P/\Delta V > 0$ , then  $D$  is decreased by  $-\Delta D$ .
- 2) If  $\Delta P > 0$  and  $\Delta V < 0$ ,  $\Delta P/\Delta V < 0$ , then  $D$  is increased by  $+\Delta D$ .
- 3) If  $\Delta P < 0$  and  $\Delta V > 0$ ,  $\Delta P/\Delta V < 0$ , then  $D$  is decreased by  $+\Delta D$ .
- 4) If  $\Delta P < 0$  and  $\Delta V < 0$ ,  $\Delta P/\Delta V > 0$ , then  $D$  is increased by  $-\Delta D$ .
- 5) If  $\Delta P = 0$ , then MPP is achieved.

For each step, taking  $E = \Delta P/\Delta V$  and considering the sign of  $\Delta P$  and  $\Delta V$ , the following conditions are concluded.

- 1) If  $E < 0$ , then  $D = D + \Delta D$ .
- 2) If  $E > 0$ , then  $D = D - \Delta D$ .

3) If  $E=0$ , then  $D=D$ .

Another type of FLC is reduced-rule FLC (RR-FLC), which improves the simplicity of FLC by reducing the computational load [27]. There are also Mamdani and Takagi-Sukeno (T-S) design approaches for FLC, where a Mamdani-based FLC is relatively popular [28]. Typically, FLC consists of three steps, fuzzification, fuzzy rules and defuzzification [29]. In the first step, the input variables are converted into linguistic variables by using various defined membership functions [30]. In the next step, these variables are manipulated based on the rules “if-then” by applying the desired behavior of the system. Lastly, these variables are converted into numerical variables [18]. The membership functions are significant in affecting the speed and accuracy of FLC [31].

Figure 3 depicts that  $E_{rr}$  and  $\Delta E_{rr}$  are two major FLC input variables while  $D$  of a DC-DC converter is the output variable to be manipulated by FLC [32]. The input variables are assigned to several linguistic variables which are denoted by negative big (NB), negative small (NS), zero (ZE), positive small (PS) and positive big (PB) [33]. The integration of FLC with M5P model tree (Quinlan’s M5 algorithm) is investigated to reduce the computation time [34]. Tables I and II present the merits and demerits as well as the recent studies of the FLC-based MPPT. In Table II, I/O stands for

input/output.

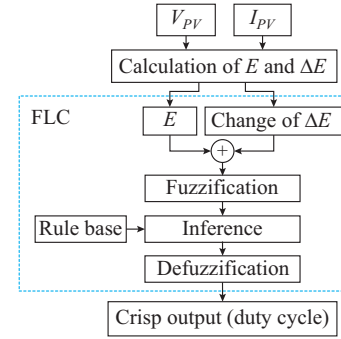

Fig. 3. Block diagram of general FLC.

TABLE I  
MERITS AND DEMERITS OF FLC-BASED MPPT TECHNIQUE

Merit	Demerit
High efficiency and small fluctuation in steady state	Difficulty in deriving fuzzy rules and time consuming
Simple design and implementation	Inability to automatically learn from the environment
Operation with inaccurate input	Complex calculation
Fast tracking speed during rapid irradiance change	Undesirable performance under PSC
Good dynamic performance	Fuzzy rules directly affect system performance
Combination with another algorithm	

TABLE II  
RECENT COMPARATIVE STUDIES OF FLC-BASED MPPT IMPLEMENTATIONS

Reference	Input parameter I/O sensor	Hardware/software platform	Solar panel	DC-DC converter	MPPT time (s)	Steady-state oscillation (%)	MPPT efficiency (%)	Finding
[35]	Voltage and current	MATLAB/Simulink and arduino	PV module (EP) 30W	Buck		±4.0		FLC is used to control MPPT in a microgrid. The steady-state performance has been improved as compared with conventional P&O method
[22]	Voltage and current	DS1104 DSpace		Boost	0.43	±1.7	98.50	Single-input T-S FLC is effective in tracking GMPP under PSC compared with conventional P&O algorithm. FLC exhibits less settling time and minimum oscillation
[26]	Voltage and current	FPGA and MATLAB/Simulink	60 W solar panel	Boost	0.3	±1.0	98.00	FPGA-based FLC is flexible as the membership functions and inference rules can be reconfigured by changing very high speed integrated circuit hardware description language (VHDL)
[28]	Voltage and current	MATLAB/Simulink	PV module (KC200GT)	Boost		±0.06	99.00	FLC is efficient in tracking GMPP value with less tracking time, compared with IC and P&O
[36]	Voltage and current	PVPM 2540C, MATLAB/Simulink	230 W poly-crystalline Si	Boost		Less than 0.01	99.37	Improved M5P model (FLC-based MPPT) proves to minimise computation time and lead to energy loss.

## B. ANN

ANN or connectionist system is inspired by the biological neural networks from animal brains. It is utilized to train and test for the non-linearity relationship between  $I-V$  and  $P-V$ . From input current, input voltage, irradiance, temperature to metrological data, ANN fetches these inputs and continuously learns to fit the behavior of the solar power system for the maximum power [37]. The design of FLC can be modelled by using ANN with higher accuracy and simpler implementation of converters [38].

From the collection of the simulation or hardware setup,

the dataset is acquired by inputting solar irradiances, temperatures, solar power system voltage  $E$  or current to ANN in finding the corresponding  $P_{max}$  or  $V_{max}$  output as shown in Fig. 4. These data are converted to the training data and to pass into the designed ANN to teach it how to perform. After the training, the test datasets are used to evaluate the performance of the designed ANN, and the errors are feedbacked to ANN for further adjustment [39]. It is deployable to assist for the prediction of MPP alongside the state estimation by the sequential Monte Carlo (SMC) filtering. A state-space model for the sequential estimation of MPP is able to

fit alongside the framework of IC MPPT technique, and the ANN model observes the voltage and current or irradiance data in predicting GMPP to refine the estimation by SMC [40].

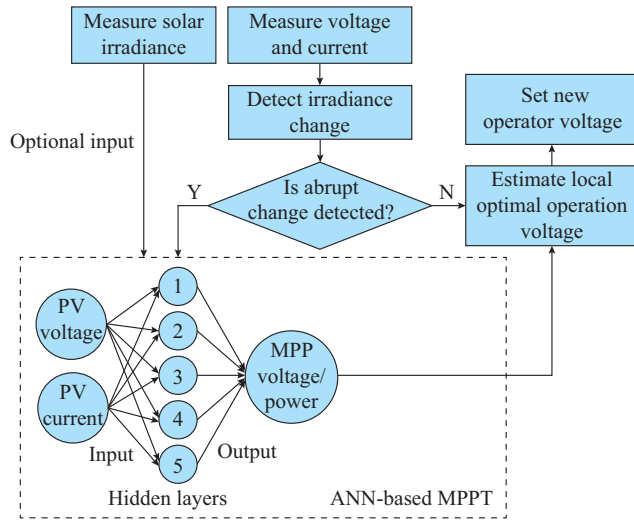

Fig. 4. Structure of an ANN-based MPPT.

The advantages of ANN include exceptional accuracy in modelling non-linearity and resolving problems without any

prior knowledge or any model [41]. ANN can be utilized in modelling and predicting the output power of the solar power system to improve the tracking speed and accuracy [42]. It is proven to have better response time and less oscillation around MPP [43]. ANN-based MPPT is proven to exhibit the capability of tracking MPP with the minimum transient time and low ripple under the real operation climatic condition [44]. The error calculation is executed by using the square error algorithm as its feedback correction [45]. However, an accurate, standardized and proper training set of data is a main limitation for the ANN to perform optimally without high training error [46]. Table III presents the merits and demerits of ANN-based MPPT. Table IV shows the recent application of ANN in MPPT.

TABLE III  
MERITS AND DEMERITS OF APPLICATION OF ANN IN MPPT

Merit	Demerit
Fast response and tracking speed	A massive dataset is required
Slight fluctuation in steady-state	Complex and time-consuming
No need to be re-programmed	Tracking accuracy is affected by the PV panel model (system dependent)
	Periodic tuning is required due to environmental change and ageing
	Difficult to be trained properly and get training data

TABLE IV  
RECENT COMPARATIVE STUDIES OF ANN-BASED MPPT IMPLEMENTATIONS

Reference	Specific type of MPPT controller	Input parameters I/O sensors	Hardware/software platform	Solar panel	DC-DC converter	MPPT time (s)	Steady-state oscillation (%)	MPPT efficiency (%)	Finding
[47]	ANN	Voltage, current, atmospheric parameter	MATLAB/Simulink and experiment	Experiment and simulated	Boost	0.06		Up to 99.68	An ANN model is deployed to learn operation variation of a solar power system. PSO is used to find optimum initial weights of ANN model
[38]	ANN modeling	Voltage and current	MATLAB/Simulink	Simulated	Boost			Above 90	MPPT based on ANN-modelled FLC exhibits higher fault tolerance and simpler implementation
[39]	Neural network	Voltage and current	MATLAB/Simulink	MSX 60 PV (simulated)	Buck Boost		±0.1		Backpropagation trained neural network can accurately predict the MPP of a PV panel. It provides accurate and faster results than P&O based MPPT
[40]	ANN	Voltage and current	MATLAB/Simulink	Simulated		0.2-0.4		Above 90	ANN model is based on the input voltage, input current and irradiance to predict GMPP with knowledge learned from training data
[48]	Feed forward ANN	Temperature and irradiance	MATLAB/Simulink	Simulated	Boost	0.03	±0.7		ANN is trained by using "nntool" in MATLAB/Simulink model. ANN based MPPT controller has less steady-state error, fast response for sudden change in solar temperature and irradiance, compared with P&O and IC

### C. GA

GA is a general AI-based optimization method applied to different optimization problems. It is widely used in MPPT to compute the voltage reference of PV panel by modifying

a population of individual solutions. In general, GA has relatively small oscillations, rapid convergence speed and fast dynamics by using voltage-step selection GA algorithm [49]. A modified GA exhibits reduced population size, simplified

mutation processes and simpler calculation of crossover [50]. Unlike conventional MPPT, GA-based MPPT is capable of searching GMPP instead of being trapped in the local MPP.

However, despite its performance, GA is not recommended to optimize very large-scale, highly complex and excessive problems due to its simplified algorithm. In the optimization process of MPPT, GA is initialized by starting the initial parent population as an array:

$$X^i = [parent^1 \quad parent^2 \quad \dots \quad parent^n] \quad (3)$$

where  $n$  is the population size; and  $parent^i$  ( $i=1, 2, \dots, n$ ) represents the initial voltage values when the algorithm starts the optimization. The objective function  $f(X^i)$  is the generated output power of the solar power system. The evaluation of fitness values for each position is executed by the objective function. Then, they are used to evolve the population and improve the population fitness through the generations. Compared with conventional GA, the algorithm must be reinitialized specifically for MPPT application because of sudden changes in load, solar irradiance or PSC. Therefore, the following conditions reinitialize the GA-based MPPT technique once they have been satisfied in (4) and (5).

$$|V(k+1) - V(k)| < \Delta V \quad (4)$$

$$\left| \frac{P(k+1) - P(k)}{P(k)} \right| > \Delta P \quad (5)$$

where  $k$  is the current measurement; and  $k+1$  is the next iteration of the measurement.

GA is invented based on the evolution of chromosomes. Figure 5 shows the typical GA process. Firstly, the initial population is encoded in binary. They are decoded into real

number and their fitness values for each chromosome are evaluated. The genetic operations including selection, crossover and mutation are performed for an optimal solution, specifically in the maximization of power output. Tables V and VI show the merits and demerits as well as the recent researches of GA-based MPPT.

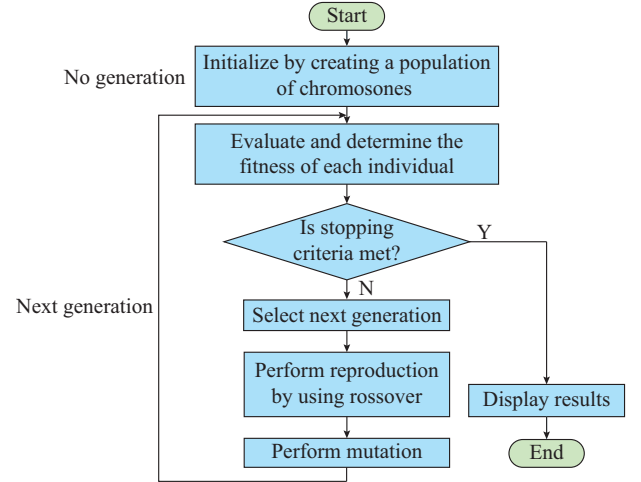

Fig. 5. Flowchart of a typical GA method in MPPT.

TABLE V  
MERITS AND DEMERITS OF APPLICATION OF GA IN MPPT

Merit	Demerit
Low computational requirement	Slow tracking speed due to series format Depending on the initial condition
General and uniform implementation scheme	
MPPT is done by function values without calculation	
High stability and rapid response	

TABLE VI  
RECENT COMPARATIVE STUDIES OF GA-BASED MPPT IMPLEMENTATIONS

Reference	Input parameter I/O sensor	Hardware/software platform	Solar panel	DC-DC converter	Finding
[51]	Temperature and irradiance	MATLAB/Simulink	HT60-156-265		A GA based on large variation radial basis function is used to learn data pattern of temperature and irradiance. The algorithm predicts MPP with high accuracy after dataset training
[49]	Voltage and current	dSpace and TerraSAS control software	SHARP NU-U235F1	Boost	GA is applied to calculate voltage reference of PV panels to combine MPPT and constant power generation in solar power systems. It imitates the performance of P&O MPPT with small power oscillations and fast dynamics
[52]	Voltage and current	MATLAB/Simulink	S440M34		GA is implemented to improve the efficiency especially under PSC which results in an overall reduction of loss energy

#### D. PSO

The most common SI-based MPPT is PSO algorithm. It is a heuristic method for resolving MPPT optimization problem. The position of a particle represents the possible solution and the duty ration represents the solution space [53]. PSO is proven to give a better-fitted result with every iteration, which is based on the concept of bird flocking. In PSO, each particle follows the best possible particle. A population of particles are presented in PSO and their positions are compared with the local best position and the global best

position. Then, these particles are moved in the search space to find the best solution [54]. PSO is available to be integrated with overall distribution (OD), which can rapidly find the rough region around GMPP [55]. An improved PSO integrates with a non-linear decreasing inertia weight in improving the search process of the particles [56]. For other modified PSO, the weighting value and learning factor decrease with every iteration. In contrast, the social learning factor is expected to increase. Besides, the weighting value is modified based on the changes in the slope and power characteris-

tic curve. These modifications increase the tracking speed and stability [57]. A discrete PSO (DPSO) is a simpler structure with higher performance and consistent solution for a smaller number of particles, compared with conventional PSO. Only one parameter is required to be tuned for the inertia weight [58].

#### E. Grey Wolf Optimization (GWO)

GWO is one of the modern heuristic optimization techniques, which is inspired by the lifestyle of the grey wolves. The leader is defined as  $\alpha$ , subleader is called as  $\beta$ , the lower rank is called as  $\delta$  and the lowest rank is called as  $\omega$ . A GWO-based MPPT is dependent on the hunting techniques of the grey wolves by obeying the order of  $\alpha$ ,  $\beta$  and  $\delta$  in the priority order. The algorithm will converge to the prey, which is GMPP in this paper.

#### F. FA

Another type of SI is FA which is based on the behavior and flashing of fireflies. The ideology is that the attractiveness is proportional to the brightness of a firefly. In this context, fireflies can converge into an optimal solution by the attractiveness. Similarly, FA can be utilized as a type of SI in MPPT to find the optimal MPP [50]. Modified cat swarm optimization (MCSO) based MPPT method is system independent and has high ability to find GMPP regardless of the location of GMPP in search space. It tracks GMPP accurately and converges faster [59]. Moth-flame optimization (MFO) is another new meta-heuristic optimization based on the convergence of moth behavior towards the light source [60].

#### G. CS

CS is an emerging SI algorithm based on the reproduction strategy of some species of Cuckoo birds that lay their eggs in the nests of other birds. CS optimization algorithm is inspired by this parasitic reproduction approach. The basis of CS is to find the right host nest, which is similar to the searching for food. It is a random process and can be modelled by using a mathematical optimization approach. The Lévy flight model is the most common method to model food seeking trajectory of an animal. Hence, in CS-based MPPT, the Lévy flight model is used to characterize the nest seeking approach of a reproduction process of Cuckoo bird. Mathematically, the Lévy flight model represents a random walk where the step sizes are defined by using Lévy distribution. It has fast MPPT speed and high tracking accuracy regardless of any weather condition. It is a simpler MPPT technique with only three particles and only one parameter to be tuned [61]. However, only the CS method does not guarantee the tracking of GMPP and is highly complex to implement [62].

#### H. Gravitational Search Algorithm (GSA)

GSA is based on the concept of Newtonian gravity and laws of motion, which states that particles tend to accelerate towards each other because they attract each other [13]. The following is the standardized steps for GSA:

1) The population size is assigned with the upper and low-

er limits of the duty cycle for the DC-DC converter, which usually ranges from 10% to 90%.

2) Solar agents are uniformly positioned between the search space intervals to achieve the optimum convergence speed.

3) For each agent position, PV output power is calculated. The power of MPPT is assumed as the mass of the agents.

4) The force  $G$  acting between the agents and the net force acting on each agent is computed.

5) The acceleration  $a$  of each agent is calculated.

Apart from conventional GSA, an improved GSA has dynamic weight in the change factor of the gravity constant. The factors of memory and population information are added into the updated formula of particle velocity [63]. Other SI algorithms including artificial bee colony (ABC), bird flocking, animal herding, bacterial growth, microbial intelligence and crowd or human swarming are inspired by biological behavior for the optimization process. Table VII shows the open issues and advantages of SI techniques for MPPT. Table VIII presents the lists of recent studies on SI-based MPPT.

TABLE VII  
MERITS AND DEMEERITS OF APPLICATION OF SI INCLUDING PSO, GWO, FA, CS AND GSA IN MPPT

Merit	Demerit
Without requiring a massive dataset	Oscillations because of large random search
High ability in searching GMPP regardless where is GMPP	Larger computational burden
Elimination of oscillation around MPP	Requiring huge data
High tracking accuracy and fast convergence	Highly complex and time-consuming
Simple structure, easy implementation and fast computation ability	Algorithm parameters need to be carefully set

#### I. Hybrid MPPT

Hybrid MPPT is a general term to describe the integration of two or more MPPT either from AI or conventional techniques. One of the most popular hybrid MPPT is the integration of ANN with conventional P&O algorithm, which is known as “neural network P&O controller” [41]. On the contrary, an improved P&O algorithm with variable step size is to reduce the steady-state fluctuation or oscillation and accelerate the tracking speed under sudden irradiance changes or PSC. ANN and FLC are suitable to integrate with conventional MPPT methods like P&O and IC. ANN estimates the MPP without any shading conditions or panel temperature, while the HC method improves the result further. Other hybrid MPPTs include PO-ANN and IC-ANN, which integrate with the stacked autoencoder (SAE) controller by using deep learning (DL) training and building blocks to act as an autoencoder. It is trained with a greedy layer-wise pattern in extracting the maximum power from the solar power system. After that, it uses backpropagation with supervised learning to fine-tune the deep neural network with conventional MPPT-IC and PO to reach the maximum power [68].

TABLE VIII  
RECENT COMPARATIVE STUDIES OF SI-BASED MPPT IMPLEMENTATIONS

Reference	Specific type of SI	Input parameter I/O sensor	Hardware/software platform	Solar panel	DC-DC converter	MPPT time (s)	Steady-state oscillation (%)	MPPT efficiency (%)	Finding
[64]	Pigeon	Voltage and current	MATLAB/Simulink	Simulated	Boost	$\pm 0.1$			A pigeon-inspired optimization is used to optimize MPPT under PSC. It reduces power oscillation, improves stability and achieves desirable control results
[53]	PSO	Voltage and current	MATLAB/Simulink	Simulated	Boost	$\pm 1.0$			PSO combined with one cycle control is able to track GMPP under varying shading conditions
[54]	PSO	Voltage and current	dSpace 1104 controller and MATLAB/Simulink	MSX-60W PV		0.4			PSO is applied for MPPT in obtaining the optimum duty cycle for the Z-source inverter to overcome the shortage of conventional MPPT technique
[55]	PSO	Voltage and current	MC56F8245 micro-processor	TC.P32 PV simulator 1000 V/13 A	Buck	$\pm 1.6$		$\pm 97.00$	OD PSO is implemented in MPPT to track MP. PSO has more power and lower power fluctuation compared with FA and P&O
[57]	Modified PSO	Voltage and current	PIC18F8720 micro-controller & MATLAB/Simulink	Sanyo HIP2717 modules	Boost	0.55-1.2			Conventional PSO has been modified to vary the weighting value, cognition learning factor, and social learning factor based on the slope and changes in power
[59]	Modified CSO	Voltage and current	DSP TMS320F28335	Chroma 62100H-600S programmable DC	Boost		$\pm 0.050$		The system-independent cat swarm optimization (CSO) has high ability to find GMPP regardless of the location of GMPP in search space. It eliminates the power oscillation around MPP compared with P&O
[60]	MFO	Voltage and current	MATLAB/Simulink	SunPower SPR305 WHT	Boost	0.05	$\pm 0.046$	99.91	MFO is applied as a novel approach for optimal exploitation of PV sources under PSC. It exhibits better performance compared with IC, FL and PSO in terms of tracking ability, efficiency and steady state
[61]	CS	Voltage and current	Microchip DSP and MATLAB/Simulink	SAS	Boost	1.8-2.8	$\pm 0.050$	$\pm 99.00$	Deterministic CS is deployed to remove the random number in the voltage calculation equation of the conventional CS method
[65]	ACO	Voltage and current	dSpace/ MATLAB/Simulink	200W PV	Cuk	0.38			Ant colony optimization (ACO) based MPPT provides optimal power extraction from solar for residential applications
[66]	Spider monkey	Voltage and current	MATLAB/Simulink	Simulated	Boost	$\pm 0.20$			P&O MPPT technique has been improved by PI controller which is tuned by spider monkey algorithm to achieve good response under different atmospheric condition
[67]	AFSA	Voltage and current	MATLAB/Simulink	PV panel emulator	Boost	$\pm 0.04$			Artificial fish swarm algorithm (AFSA) method can easily avoid the constraint of multiple local extreme value points and catch MPP of the current environment with high precision
[63]	GSA	Irradiance and temperature	MATLAB/Simulink	Simulated	Boost	$\pm 0.04$	$\pm 1.000$		Improved GSA-based MPPT achieves short tracking time and good tracking accuracy in MPPT under various of conditions compared with GSA and PSO

Another popular hybrid MPPT is an adaptive neuro-fuzzy inference system (ANFIS) which integrates ANN and FLC together. It has the advantages of both ANN and FLC. ANN is trained to estimate the optimal MPP and used to drive an FLC-based MPPT. ANFIS and fuzzy logic are optimal, flexible and adaptable to any new configuration for smart power management and solar power system [69]. Neuro-adaptive learning technique is used to model fuzzy procedure in learning all the information about a dataset. It is a process to map all the given dataset from multiple inputs into a single output. By using input-output datasets, ANFIS constructs a

fuzzy inference system. The model computes the membership function parameters, which are the best fit in allowing FIS to track the input and output data [70]. The fuzzy membership function parameters are adjusted by utilizing a hybrid learning method, including backpropagation and least square algorithms [71]. ANFIS-based MPPT is proven to improve the conversion efficiency of the solar power system [72]. The fuzzy neural network is also capable of bit error correction in predicting and forecasting weather data for solar power system [73].

ANN is deployable based on hybrid PSO and GSA, along-

side with FLC. For instance, PSO-GSA generates a random initial population first and send them to ANN for data training [74]. Another hybrid MPPT technique is based on improved open-circuit voltage model-based approach and smart power scanning procedure. The smart power scanning checks the voltage values to see whether PSC is happening or not [75]. Apart from ANN, FLC is also versatile to integrate with P&O algorithm. It combines both technique advantages together [16]. FLC-based P&O has a variable step size to ensure small oscillation and faster response because big step size ensures fast response but leads to excessive oscillation whereas small step size has slow response and less oscillation [76]. The integration of the IC method with PSO algorithm is also available to resolve the inability of conventional MPPT in tracking GMPP under PSC while improving the convergence speed and tracking precision [77].

Another hybrid MPPT is the integration of two powerful machine learning (ML) techniques, coarse-Gaussian support vector machine (CGSVM) and ANN, which is known as ANN-CGSVM technique. CGSVM is a type of non-linear SVM learning technique categorized as a data mining technique [78]. Rational quadratic Gaussian process regression (RQGPR) is required in generating large and accurate training data for MPPT, as well as integrating ANN and RQGPR

to utilize data mining and regression learner for PV MPPT [79]. A novel ANFIS with HC (ANFIS-HC) combines the ANFIS controller with HC method to offline estimate the duty ratio with higher accuracy. HC carries on an online fine-tuning of the duty cycle, which resolves the problem of conventional MPPT in searching GMPP under PSC since the duty ratio of MPP is estimated offline by the ANFIS technique [80]. The classical ML algorithms, including support vector machine (SVM) and extreme learning machine (ELM) are available to be integrated with fuzzy-weighted classification labelling. Provided by a supervised learning classification system, this integration enables the determination of optimal step size according to the weather information [81]. Tables IX and X present the recent researches of hybrid MPPT as well as the merits and demerits, respectively.

TABLE IX  
MERITS AND DEMERITS OF HYBRID MPPT

Merit	Demerit
Combination of conventional and AI-based MPPT advantages	Relatively complex
Cancellation of disadvantages of conventional and AI-based MPPT	Longer computational time Costly
High accuracy and fast-tracking speed	

TABLE X  
RECENT COMPARATIVE STUDIES OF HYBRID MPPT IMPLEMENTATIONS

Reference	Specific type of MPPT controller	Input parameter I/O sensor	Hardware/software platform	Solar panel	DC-DC converter	MPPT time (s)	Steady-state oscillation (%)	MPPT efficiency (%)	Finding
[82]	FLC with PSO and GA	Voltage and current	MATLAB/Simulink		Boost	$\pm 0.200$			Parameters of an FLC are tuned by using hybrid PSO and GA. It exhibits 2%-8% higher output power with faster response rate and higher accuracy
[83]	ANFIS-PSO	Voltage and current	MATLAB/Simulink linked to dSPACE DS1104 board		Zeta	$\pm 0.300$		98.35	ANFIS-PSO hybrid MPPT is deployed to acquire MPP with zero oscillation tracking
[31]	FLC with P&O	Voltage and current	MATLAB/Simulink	Simulated under EN 50530 standard	Boost	$\pm 1.000$	$\pm 0.01$	99.6	The designed membership functions of FLC incorporate the advantages of the P&O-MPPT and the FL-MPPT and eliminate their drawbacks
[50]	Modified GA and FA	Voltage and current	Labview, MATLAB/Simulink, cypress, PSoC4 ARM cortex-M0	IV curve simulator	Buck	0.089	$\pm 2/3$		A fusion algorithm is deployed to integrate three nature-inspired algorithms for MPPT. It simplifies the calculation of GA with the integration of the mutation process of DE and modifies the attractive process of FA
[84]	FLC with variable step P&O	Voltage and current	dSpace		Boost	$\pm 0.030$	0.05		FLC is developed to regulate DC-link while an improved P&O with variable step size is designed to reduce PV power fluctuation
[68]	Hybrid intelligent controller (PO-ANN and IC-ANN)	Voltage and current	MATLAB/Simulink	SHARP 80W	Cuk	$\pm 0.400$		>91.00	The hybrid techniques based on PO-ANN and IC-ANN are utilized in SAEs. It is trained with DL network and building blocks to enable the maximum power extraction from solar.
[71]	ANFIS	Voltage and current			Buck	0.012		91.00	ANFIS-based model on top of IC method and constant voltage method has been proposed for MPPT



*J. ML*

Bayesian ML is a method specialized in unsupervised classification, curve detection, and image segmentation. It is applicable in MPPT to achieve GMPP [85]. The real-time location-based weather forecasting is also applicable by using optimized modified ELM or Bayesian ML (BML). In order to train a single layer feed-forward network, ELM algorithm is utilized to update the weights by different PSO techniques. Their performances are compared with existing models like the back-propagation forecasting model [86]. As illustrated in Fig. 6, reinforcement learning (RL) method enables autonomous learning by observing the environment state of the solar power system. It is used to train and adjust the perturbation for the maximum output. Table XI shows the merits and demerits of ML-based MPPT, while Table XII presents the recent studies.

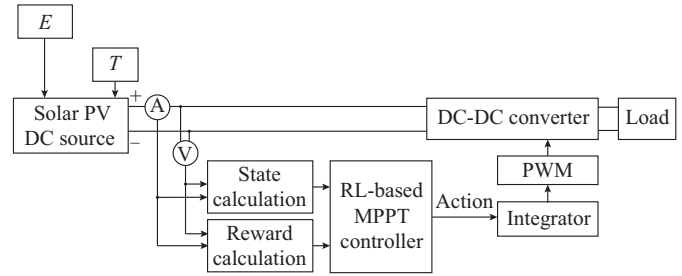

Fig. 6. General structure of RL-based MPPT.

TABLE XI  
MERITS AND DEMERITS OF ML-BASED MPPT

Merit	Demerit
Able to take more variables into consideration	Highly complex and costly
Weather forecast for MPPT prediction	A huge amount of data is required
High accuracy and fast-tracking speed	Longer computation time

TABLE XII  
RECENT COMPARATIVE STUDIES OF ML-BASED AND OTHER MPPT IMPKEMENTATIONS

AI-based MPPT	Reference	Specific type of MPPT controller	Input parameter I/O sensor	Hardware/software platform	Solar panel	DC-DC converter	MPPT time (s)	Steady-state oscillation (%)	MPPT efficiency (%)
ML	[85]	BML	Voltage and current	MATLAB/Simulink and plss controller		Boost	±1.88	Almost zero	98.9
	[86]	Modified ELM	Voltage and current	MATLAB/Simulink	Simulated			±1	
Others	[87]	DE	Voltage and current	PIC18F4520 micro-controller	Mitsubishi PV in solar array simulator	SEPIC	±2.00		99.0
	[88]	Modified FPA	Voltage and current	MATLAB/Simulink	Simulated	Boost	0.05		99.1

*K. Development of New AI-based MPPT and other Emerging Metaheuristic Algorithms*

DE-based MPPT is an optimization method to use target vectors as the population in each iteration. The more particles are used, the larger the search space, the slower the convergence speed. DE is meta-heuristics since it searches very large spaces of possible solutions and does not guarantee an optimal solution [87]. Another emerging algorithm is a modified flower pollination algorithm (FPA) which is inspired by the pollination process of flowers. Cross-pollination requires communicators including birds, bees and bats while self-pollination is the propagation of mature pollens by the wind. This process is referred to complete local optimization [88]. Other emerging algorithms are evolutionary algorithm (EA) [89] and TS [90]. EA is a generic population-based metaheuristic algorithm based on biological evolution which includes reproduction, mutation, recombination and selection. TS is another metaheuristic search method using local search methods for mathematical optimization. Table XIII shows the recent studies of other emerging AI for MPPT control strategies.

III. ANALYTICAL COMPARISON OF AI-BASED MPPT TECHNIQUES

*A. Classification of AI-based MPPT Techniques*

The AI-based MPPT techniques are compared with re-

gards to the following parameters: ① tracking speed for MPP; ② tracking accuracy; ③ steady-state oscillation; ④ complexity of the algorithm which affects the computation time; ⑤ overall cost. The general classification of the popular AI-based MPPT techniques is categorized as FLC, ANN, SI, hybrid, GA, ML and other new emerging algorithms, according to their descending popularity. There are other emerging algorithms which may not be included in this paper due to the limited space and constrained area. Approximate citation popularity of AI-based MPPT versus year is shown in Fig. 7.

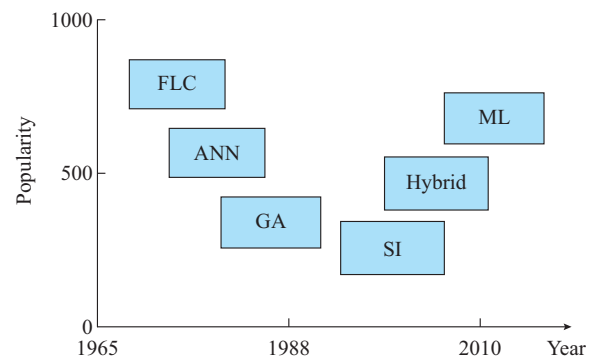

Fig. 7. Approximate citation popularity of AI-based MPPT versus year.

FLC is invented in the year 1965, and it is popular in that

decade. After that, ANN, GA, SI, hybrid and ML are invented at a respective timeline, and all of them are still applicable in AI-based MPPT over the decades. In the result section, there are three major comparative tables and one categorization figure. The tables include the merits and open issues for each AI-based MPPT, the comparison of parameters between all AI-based MPPT, and the available AI-based MPPT in recent years.

The categorization figure presents a clear representation of available AI-based MPPT in each category and classifications. Generally, the evaluation of AI-based MPPT techniques is executed in terms of several parameters and features which include the number of control variables (input sensory parameters), the utilized platform (software: MATLAB/Simulink; hardware: arm cortex microcontroller, Arduino, Raspberry Pi, and DSP board-dSpace), the solar panel parameters, the switching frequency of DC-DC converter, the type of DC-DC converters (buck, boost, buck-boost, Ćuk or SEPIC), tracking/convergence speed or transient time, oscillation accuracy and MPPT efficiency. In recent years, bio-inspired algorithms and ML are very popular due to their sophistication in terms of accuracy, speed and performance. More parameters are considered as input parameters instead of only current and voltage inputs. It includes the humidity, shading, cloud and metrological data. All algorithms aim to have fast convergence or tracking speed, low steady-state oscillation, simple cost-effective implementation, fast computational capability and high efficiency with the minimum power loss.

**B. Comparison**

The recent AI-based MPPT techniques are typically more advanced and efficient but require a huge amount of data, highly complex and costly. The balance between the performance and the cost or complexity is critical for the application of MPPT in a specific area. Figure 8 categorizes the recent popular AI-based MPPT techniques into seven major groups, namely FLC, ANN, SI, hybrid, GA, ML and emerging algorithms.

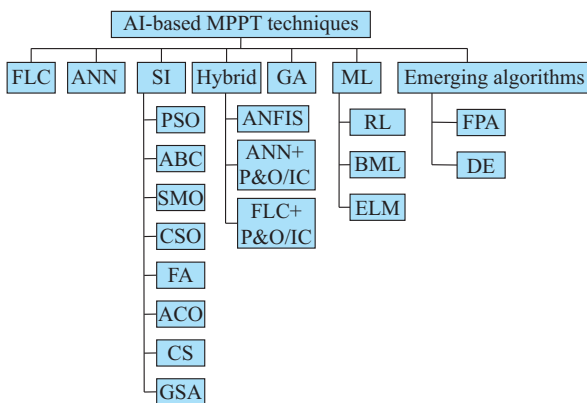

Fig. 8. Classification and categorization for popular AI-based MPPT techniques in recent years.

The family of SI is the largest in AI-based MPPT, mainly because its algorithms are inspired by biological swarm intelligence (SI) due to fast performance and high accuracy. The hybrid and ML have a great variety of sub-categories. The

hybrid MPPT is relatively versatile as the AI-based MPPT is easily integrated with each other. ML is another popular technique. It has various approaches and techniques to learn from the experience or dataset in order to output the maximum power. FLC, ANN, and GA do not have any sub-categories. The emerging algorithms have the latest advancing techniques in MPPT, which is continuously improving and populating.

As illustrated in Figs. 9 and 10, all AI-based MPPT techniques are evaluated in term of the performance evaluation in each category and total evaluation point, respectively. Points 0-10 imply the performance compared with other algorithms, where point 10 indicates high performance while point 0 indicates undesirable performance. The scoring is based on Table XIII. The results are established based on the literature reviews on existing studies and validated by the simulation results on MATLAB/Simulink. It is concrete that SI has scored the highest point in average, followed by hybrid, ML and GA. They are meta-heuristic methods which are able to adapt to the operation environment of the solar power system. The balance between algorithm complexity and desirable MPPT performance is achievable by using SI, hybrid MPPT, ML or GA techniques.

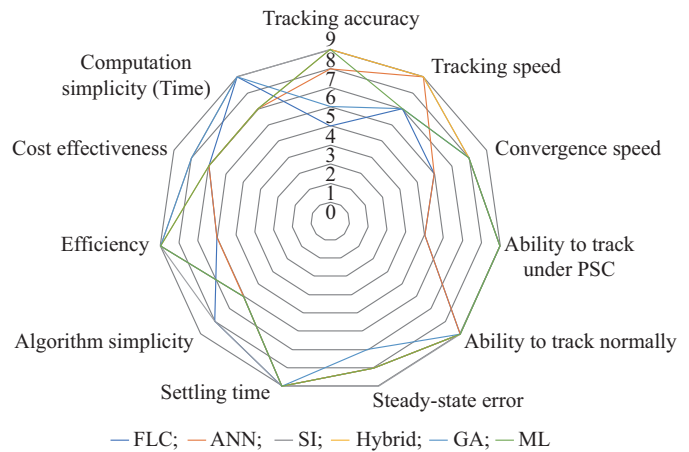

Fig. 9. Performance evaluation of each AI-based MPPT in term of each category.

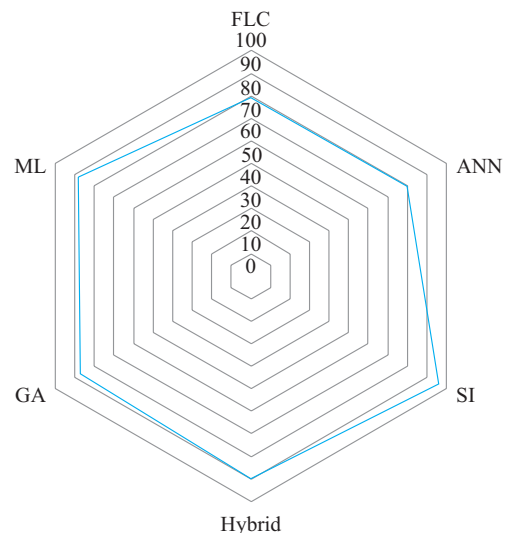

Fig. 10. Performance of AI-MPPT techniques.

TABLE XIII  
COMPARISON OF AI-BASED MPPT TECHNIQUES IN TERM OF PARAMETERS

Index	FLC	ANN	SI	Hybrid	GA	ML
Tracking accuracy	Moderate	High	High	High	Moderate	High
Tracking speed	Moderate	Fast	Fast	Fast	Moderate	Moderate
Convergence speed	Moderate	Moderate	Fast	Fast	Fast	Fast
Ability to track under PSC	Poor	Poor	High	High	High	High
Ability to track normally	High	High	High	High	High	High
Steady-state oscillation	Small	Small	Almost Zero	Small	Moderate	Small
Oscillation around MPP	No	No	No	No	No	No
Settling time	Fast	Fast	Fast	Fast	Fast	Fast
Complexity	Moderate	High	Moderate	High	High	High
Parameters required (sensor)	Voltage and current	Irradiance, temperature, voltage and current	Voltage and current (varies)	Varies	Voltage and current (varies)	Varies
Periodic tuning	Yes	Yes	No	No	No	No
Dependency of initial design	High	High	Moderate	Moderate	Moderate	Moderate
System independence	Poor	Poor	High	High	High	High
Efficiency	Poor (PSC)	Poor (PSC)	High	High	High	High
Cost	High	High	Moderate	High	Moderate	High
Computation time	Moderate	High	Moderate	High	Moderate	High
Algorithm complexity	Medium	Medium	Simple	High	High	High
Application	Grid and solar vehicles	Grid, water pump, solar vehicles and motor drives	Off-grid and on-grid	Off-grid and on-grid	Off-grid and on-grid	Off-grid and on-grid

Table XIII presents a detailed comparison between AI-based MPPT in terms of the performance indices such as tracking accuracy, tracking speed, convergence speed, ability to track under PSC and others. It is observed that older AI-based MPPT techniques such as FLC and ANN have relatively poor performance in terms of convergence speed and their ability to track under PSC. Under PSC or sudden change of irradiance, continuous periodic tuning process is required in the converter switch to track MPP. For ANN, a massive dataset is required to design a proper ANN-based MPPT with high accuracy, difficulty in training and higher time consumption. For FLC, it is difficult to derive its fuzzy rules accurately and unable to learn actively from the dynamic environment and perform undesirably. In contrast, SI, hybrid GA and ML exhibit faster speed and high ability in tracking even under PSC owing to their newer architecture

which combines the advantages of conventional HC MPPT and the latest advancement of AI.

#### IV. SIMULATION RESULTS

##### A. Simulation Setup and Configuration

To validate and compare the performance of AI-based MPPT techniques, an extensive simulation based on MATLAB/Simulink R2020a is conducted. The simulation setup is to study, evaluate and investigate the dynamic behavior of the AI-based MPPT under PSC. The optimal MPP is benchmarked against the searching process of each AI-based MPPT. As illustrated in Fig. 11, the block diagram presents the simulation environment in a standalone solar power system.

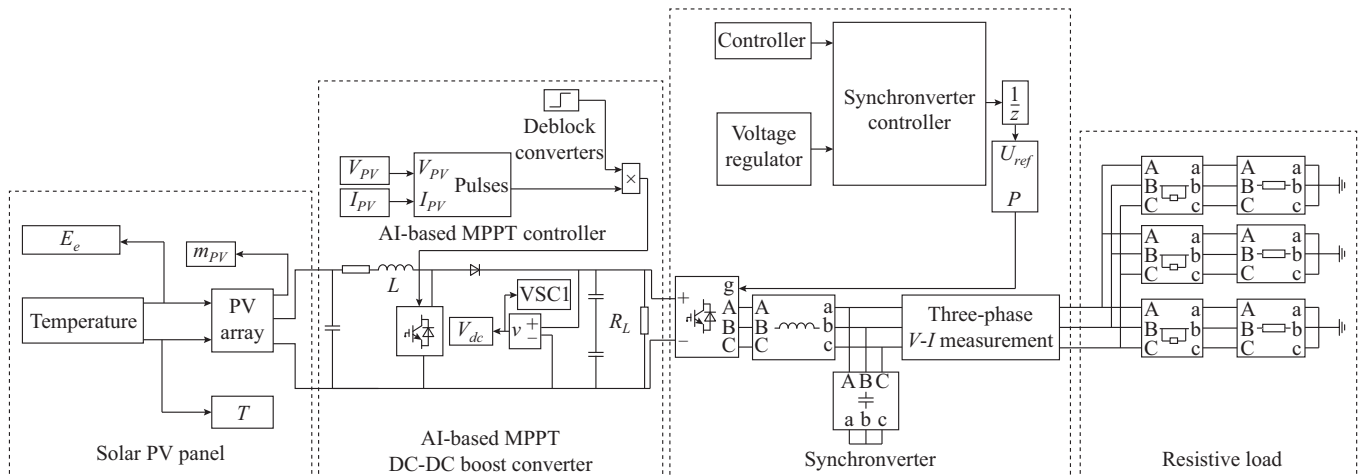

Fig. 11. MATLAB/Simulink simulation for comparison of AI-based MPPT.

The PV panel SunPower module (SPR-305E-WHT-D) inputs with varying solar irradiance  $E_e$  and  $T$ . It is simulated under PSC to emulate the practical environment. A 5 kHz DC-DC boost converter is designed and its insulated-gate bipolar transistor (IGBT) switching devices are controlled by the AI-based MPPT controller to output the most optimized voltage and current for MPP.

A DC-AC converter (inverter) based on synchronverter topology is deployed to convert optimized solar MPPT of DC output to AC output in supplying AC for the three-phase balanced resistive load  $R_L$ . The MPPT controller is the variable that has been changed from FLC, ANN, SI, hybrid, GA to ML to compare their tracking ability for MPP under PSC, which is validated as shown in Table XIV. Other emerging techniques are not included in the simulation because of their dynamic development and constantly-changing algorithms. Two case studies have been executed to study the MPPT ability under PSC and normal conditions with constant irradiance and temperature. The power output is at the DC output of the DC-DC boost converter for evaluating the optimized MPPT output. The simulation results are then compared and validated as shown in Table XIV.

TABLE XIV

COMPARISON OF AI-BASED MPPT TECHNIQUES IN TERM OF PARAMETERS

AI-based MPPT	Tracking time (s)	Steady-state oscillation (%)	Affected by PSC/ varied irradiance
FLC	0.70	$\pm 3.0$	Yes
ANN	0.25	$< 1.0$	Yes
SI	0.28	$\pm 1.7$	No
Hybrid	0.23	$\pm 0.1$	No
GA	0.80	$\pm 10.0$	No
ML	0.60	$\pm 1.5$	Slightly

As shown in Fig. 12, the solar panel characteristic graphs of  $I-V$  and  $P-V$  are plotted under standard test condition (STC) at the temperature of 25 °C and solar irradiance level of 1000 W/m<sup>2</sup>. Figure 12(a) presents the  $I-V$  and  $P-V$  characteristics when the irradiance varies while the temperature remains constant at 25 °C. On the contrary, Fig. 12(b) presents the  $I-V$  and  $P-V$  characteristics when the temperature varies while the irradiance remains constant at 1000 W/m<sup>2</sup>. The non-linearity of  $I-V$  and  $P-V$  from a solar power system is the main reason of an AI-based MPPT to search for MPP with different irradiance and temperature.

### B. PSC Analysis

PSC analysis is conducted by emulating PSC for the inputs of the solar panel. To simulate PSC, the current is adjusted to allow multiple peaks in the  $P-V$  curves. Besides, MPPT failure caused by dynamic irradiance changes is investigated. The current source of solar cells is adjusted automatically using the look-up table. The PSC effects on the solar module are accounted for, which enables partial shading on certain cells. The phenomenon is common for the practical environment where partial shading occurs when there are dirt, leaf, cloud, tree and other obstacles that block the sunlight. Figure 13 shows the local MPP and GMPPT performance by the AI-based MPPT under PSC.

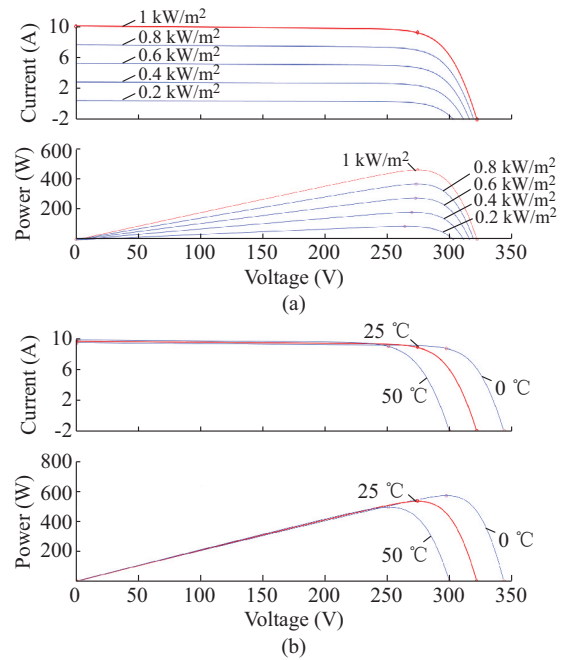

Fig. 12.  $I-V$  and  $P-V$  curves of solar panel under STC. (a) With constant temperature at 25 °C and varying irradiance. (b) With constant irradiance at 1000 W/m<sup>2</sup> and varying temperature.

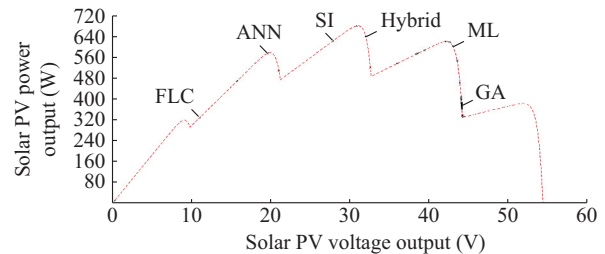

Fig. 13. Local MPP and GMPPT performance for AI-based MPPT under PSC.

It is self-explanatory that SI and hybrid MPPT are performing optimally by tracking GMPP, which is the highest possible output of solar power system. This is because of the algorithm optimization, population searching ability and combination of different algorithms. ML and ANN are also performing well while GA tracks the local MPP with some steady-state oscillations. However, the performance of FLC is relatively unsatisfactory owing to its slow transient response and inability to track GMPP. It is trapped at the local MPP and results in lower power conversion efficiency.

### C. MPPT Ability

The tracking ability of AI-based MPPT controller for MPP with constant irradiance is simulated. Figure 14(a)-(f) shows MPPT ability of different algorithms. The dotted blue line indicates the optimal MPP at approximately 650 W with normal irradiance and temperature. The red line indicates the output power of solar power system as the AI-based MPPT tracks and suggests MPP to extract the maximum power from the solar power system. It is observed that the performance of AI-based MPPT is relatively satisfactory except for FLC.

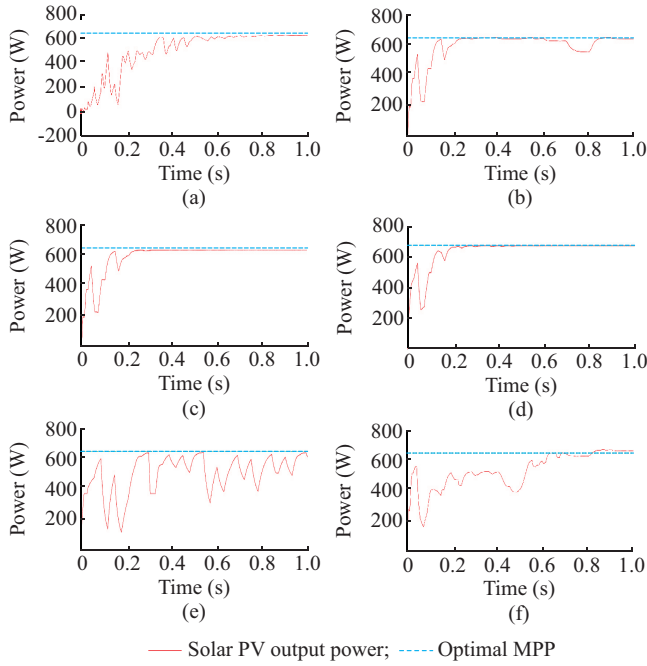

Fig. 14. MPPT ability of different algorithms. (a) FLC. (b) ANN. (c) SI. (d) Hybrid. (e) GA. (f) ML.

#### D. Comparative Analysis and Validation of Results

Table XIV summarizes and presents the comparison of AI-based MPPT techniques in terms of MPPT time, steady-state oscillation at MPP and the ability to resist the adverse effect of PSC or varying irradiance, which occurs at around  $t=0.7$  s. It is observed that FLC is underperforming by exhibiting higher tracking time for MPP with high SSE and affected by PSC. However, SI and hybrid-based MPPT perform satisfactorily with the minimum tracking time, low SSE and the minimum disturbance under PSC. These analyses are tally with Table XIII and the findings from the existing literature and researches on AI-based MPPT. Both simulation results and literature review findings are mutually verified and validated. Nevertheless, different scenarios and applications result in different choices of AI-based MPPT. Hence, it is recommended to choose the appropriate and most suitable AI-based MPPT based on the design criteria and requirements.

## V. DISCUSSION

The extensive comparison and investigation on various AI-based MPPT have clearly shown that each algorithm has its own merits and demerits. The choice of algorithm is solely depending on the choice of the designer. Typically, the input parameters of MPPT are  $V_{in,pv}$  and  $I_{in,pv}$ , which are acquired through voltage and current sensors.  $P_{in,pv}$  is then computed by using  $P_{in,pv} = V_{in,pv} I_{in,pv}$ . However, solar irradiance, temperature, metrological data of humidity and shading are required to train AI. Irradiance and temperature are used by some MPPT techniques to define MPP [91]. AI is deployed to predict current and voltage while taking input variability of MPPT and non-linearity relation between  $I-V$  and  $P-V$ . The model can better estimate the voltage chosen by MPPT by using historical data. The performance and accuracy of the

MPPT techniques can be influenced by the voltage step. When the voltage step is too small, it takes longer time to reach MPP. If the voltage step is too large, although it takes shorter time to reach MPP, MPP cannot be reached because of the excessive oscillation around MPP [92]. To check the convergence speed or tracking speed, a sudden change in irradiance is required as an input to observe the output of MPPT, whether it is in response to the rapid changes of input [93]. EN 50530 [31] is a standardized test to evaluate the efficiency of MPPT by providing triangular waveforms of irradiance with different ramp gradients. It is also used to provide rapid change or PSC situation in testing the response and performance of MPPT. In general, the normal conditions of an MPPT testing environment presume that the temperature is 25 °C, the maximum solar irradiance level is at 1000 W/m<sup>2</sup> and the angle of incidence  $\alpha$  is 90° [16].

Another important aspect of AI-based MPPT is to search for GMPP under PSC or varying irradiance and temperature. The failure of MPPT could be caused by the inability of the algorithm to search for GMPP. It will be stuck at the local MPP and thus cannot produce the optimal power output. In general, SI approaches are based on the searching for the optimal solution in the search space. The acting participants in the optimization can be a reminiscence of an ant for ACO [94], a monkey for spider monkey optimization (SMO), a cuckoo for CS and a firefly for FA. The conditional algorithm detects the fulfilment of the maximum power by setting a range. The oscillations are caused by the fluctuation of an operation point, non-uniform distributed solar insolation, the inability of the algorithm in identifying GMPP when there are many other local MPPs. In terms of performance parameters, the oscillation time is the period between the changes until the output enters into steady state, i.e., no more oscillation. The tracking speed or convergence speed indicates how fast MPPT tracks the real MPP. In contrast,  $\eta$  is defined as the power tracked by MPPT or output power  $P_{out} = V_{out} I_{out}$ , divided by  $P_{MPP}$ , which is equal to  $V_{MPP} I_{MPP}$ . The settling time is required for the steady-state form without any oscillation [95]. The choosing criteria of AI-based MPPT are based on the implementation complexity, required sensors, the ability to detect multiple local maxima, response time, costing and its application, transient time, settling time, steady-state error, overshoot and ripples in the output voltage of PV panel [96]. Generally, the conventional or HC methods fail to track GMPP under PSC. They have oscillations around MPP during the steady state, and longer time are required in tracking MPP with lower efficiency. However, AI-based MPPT techniques do not exhibit the drawbacks of conventional MPPT but require higher cost, complex computation and modelling. Overall, the hybrid methods are the best among all algorithms, since it combines and integrates two or more algorithms, which contributes to the mutual cancellation of open issues [31]. The validation of the experimental result is usually conducted by the comparison, evaluation and analysis between simulation and experimental results.

Apart from MPPT, an inverter is the medium interface between the solar power system and the power grid. Hence, an

efficient inverter is important for converting DC to AC and acting as anti-islanding protection [97]. An improved inverter optimizes the power extraction without adversely affecting the PV DC output to AC [98]. Proportional integral derivative (PID) controller is recommended to regulate  $D$  output to pulse width modulation from MPPT techniques due to its flexibility, stability, the minimum overshoot, fine-tuning characteristic, the minimum rise time for output voltage and performance optimization [85], [99]. Generally, AI-based MPPT techniques are applicable for grid-connected (on-grid), standalone (off-grid) and other specialized applications including solar vehicle, solar lamp, water heater, DC motor, and water pump. On-grid is connected to the electric utility grid while off-grid is directly connected to loads.

## VI. RECOMMENDATIONS AND FUTURE RESEARCH DIRECTION

This section aims to recommend AI-based MPPT to be applied in the solar power system and their future research areas. The traditional MPPT techniques are phasing out since the latest AI-based MPPT techniques have better performance and stability. The development of the AI-based MPPT is dependent on the latest advancement in ML and DL. The main challenges include the ability to search for GMPP and the complexity of the algorithm.

For the conventional MPPT such as open current, open voltage, P&O and IC, they are recommended for simple and low-cost application which does not require high performance. In order to resolve, optimize and predict the non-linearity of the PV cell without staying at local MPP under PSC, the AI-based MPPT techniques are recommended for optimal performance, accuracy and convergence speed. For the type of EA, GA is faster than classical methods, but it tends to stick at local minima. The improved GA requires higher computation resources and different parameters require tuning. In contrast, DE is fast and accurate without any employment of probability distribution. However, its population can be stagnant in some sub-optimal values. PSO has the highest performance by considering different best positions to update the population, which is also simple to be implemented in hardware and independent from the installed system [100]. However, it tends to converge prematurely and can be trapped at local minima. The choice of AI-based MPPT method is dependent on the design choice, application and design requirement. For the maximum performance, PSO is recommended due to its maturity compared with GA. DE is better than GA in term of accuracy and computation time while GA is faster than classical methods. GA and DE techniques can track the GMPP under PSC because of their capabilities of resolving multi-objective problems. For the applications which are sensitive to the power fluctuation such as household appliances, motor, extreme low voltage (ELV), light sources, electro-heat equipment, electrical machine, uninterruptible power source (UPS), computer, and electronic devices, CS and radial movement optimization (RMO) are recommended owing to their faster convergence speed to settle at GMPP with minimal fluctuation.

Theoretically, the occurrence of voltage fluctuation is defined as a continuous change in the voltage when devices or

appliances that require a higher load are extensively used. The parameters of an AI-based MPPT controller are the design complexity, ability to track GMPP, cost-effectiveness, PV panel dependency, prior training requirement, dataset requirement, convergence speed, analogue or digital architecture, required sensory information, periodic tuning, stability, SSE, efficiency, and TET. The balance between the complexity and performance of the algorithm should be considered when designing AI-based MPPT. In the general context, the higher the performance of AI-based MPPT, the more complex the designed algorithm. Therefore, TET and computation time are affected.

The most critical aspects of the AI-based MPPT are the ability to track GMPP. Besides, real-time solar panel experiments lack concrete evidence. A general design flow for the standardized AI-based MPPT is in lack of studies. In a grid-connected solar power system, MPPT is also a crucial element to be integrated with synchronverter to act as a DC-DC-AC converter, which is to provide the maximum power extraction and virtual inertia concurrently [101]. The stabilization of the grid voltage and frequency output of the solar power system at the AC grid side is guaranteed and maintained [102]. High power efficiency is ensured with the minimum grid frequency and voltage fluctuation.

## VII. CONCLUSION

We provide a detailed comparison of popular AI-based MPPT techniques for the solar power system. They are designed to track GMPP instead of local MPP in alleviating the effects of PSC. Each technique is compared in terms of algorithm structure, cost, complexity, platform, input parameters, tracking speed, oscillation accuracy, efficiency and their applications. The AI-based MPPT techniques are generally classified into FLC, ANN, SI, hybrid, GA, ML and other emerging techniques. Generally, all of them exhibit good convergence speed, small oscillation at steady state and accurate tracking, even under PSC or rapid change of irradiance. However, most of the techniques are costly and complex to build and require more datasets compared with conventional MPPT techniques. Compared with FLC, ANN, and GA, other emerging and newer algorithms including hybrid, SI, ML and DL are also recommended due to their newer architectures with adaptive learning capabilities, fully digitalized system and fewer open issues. In contrast, ANN and FLC are not much preferred due to their ageing architecture, periodic tuning requirement and inability in tracking MPP under PSC. This review is expected to provide a detailed insight into the latest advancement of AI-based MPPT techniques for the application in the solar power system.

## REFERENCES

- [1] S. Kanwal, B. Khan, and M. Q. Rauf, "Infrastructure of sustainable energy development in Pakistan: a review," *Journal of Modern Power Systems and Clean Energy*, vol. 8, no. 2, pp. 206-218, Mar. 2020.
- [2] X. Chen, M. B. McElroy, Q. Wu *et al.*, "Transition towards higher penetration of renewables: an overview of interlinked technical, environmental and socio-economic challenges," *Journal of Modern Power Systems and Clean Energy*, vol. 7, no. 1, pp. 1-8, Jan. 2019.
- [3] S. Bhattacharyya, D. S. K. Patnam, S. Samanta *et al.*, "Steady output

- and fast tracking MPPT (SOFT MPPT) for P&O and InC algorithm,” *IEEE Transactions on Sustainable Energy*. doi: 10.1109/TSTE.2020.2991768
- [4] Y. Yang and H. Wen, “Adaptive perturb and observe maximum power point tracking with current predictive and decoupled power control for grid-connected photovoltaic inverters,” *Journal of Modern Power Systems and Clean Energy*, vol. 7, no. 2, pp. 422-432, Mar. 2019.
- [5] K. Y. Yap, H. Chua, M. J. K. Bashir *et al.*, “Central composite design (CCD) for parameters optimization of maximum power point tracking (MPPT) by response surface methodology (RSM),” *Journal of Mechanics of Continua and Mathematical Sciences*, vol. 1, no. 1, pp. 259-270, Mar. 2019.
- [6] A. Ibrahim, S. Obukhov, and R. Aboelsaud, “Determination of global maximum power point tracking of PV under partial shading using cuckoo search algorithm,” *Applied Solar Energy*, vol. 55, pp. 367-375, Mar. 2020.
- [7] C. Correa-Betanzo, H. Calleja, C. Aguilar *et al.*, “Photovoltaic-based DC microgrid with partial shading and fault tolerance,” *Journal of Modern Power Systems and Clean Energy*, vol. 7, no. 2, pp. 340-349, Mar. 2019.
- [8] M. Chen, S. Ma, J. Wu *et al.*, “Analysis of MPPT failure and development of an augmented nonlinear controller for MPPT of photovoltaic systems under partial shading conditions,” *Applied Sciences*, vol. 7, no. 1, pp. 95-116, Jan. 2017.
- [9] D. P. Mishra and S. Chakraborty, “Application of soft computing in simulation of solar power tracking,” in *Proceedings of 2018 Technologies for Smart-City Energy Security and Power (ICSESP)*, Bhubaneswar, India, Jun. 2018, pp. 1-5.
- [10] L. Zhang, S. Yu, T. Fernando *et al.*, “An online maximum power point capturing technique for high-efficiency power generation of solar photovoltaic systems,” *Journal of Modern Power Systems and Clean Energy*, vol. 7, no. 2, pp. 357-368, Mar. 2019.
- [11] L. L. Jiang, R. Srivatsan, and D. L. Maskell, “Computational intelligence techniques for maximum power point tracking in PV systems: a review,” *Renewable and Sustainable Energy Reviews*, vol. 85, pp. 14-45, Apr. 2018.
- [12] M. Séné, F. Ndiaye, M. E. Faye *et al.*, “A comparative study of maximum power point tracker approaches based on artificial neural network and fuzzy controllers,” *International Journal of Physical Sciences*, vol. 13, pp. 1-7, Jan. 2018.
- [13] M. G. Batarseh and M. E. Zater, “Hybrid maximum power point tracking techniques: a comparative survey, suggested classification and un-investigated combinations,” *Solar Energy*, vol. 169, pp. 535-555, Jul. 2018.
- [14] O. Abdalla, H. Rezk, and E. M. Ahmed, “Wind driven optimization algorithm based global MPPT for PV system under non-uniform solar irradiance,” *Solar Energy*, vol. 180, pp. 429-444, Mar. 2019.
- [15] Á.-A. Bayod-Rújula and J.-A. Cebollero-Abián, “A novel MPPT method for PV systems with irradiance measurement,” *Solar Energy*, vol. 109, pp. 95-104, Nov. 2014.
- [16] R. Gimazov and S. Shidlovskiy, “Simulation modeling of intelligent control algorithms for constructing autonomous power supply systems with improved energy efficiency,” in *Proceedings of International Scientific and Practical Conference*, Toms, Russia, Feb. 2018, pp. 1-5.
- [17] A. Kihal, F. Krim, B. Talbi *et al.*, “A robust control of two-stage grid-tied PV systems employing integral sliding mode theory,” *Energies*, vol. 11, pp. 2791-2811, Oct. 2018.
- [18] D. I. Ighneiwa and A. A. Yousuf. (2018, Feb.). Using intelligent control to improve PV systems efficiency. [Online]. Available: <https://arxiv.org/abs/1802.03463>
- [19] A. Abbadi, F. Hamidia, A. Morsli *et al.*, “MPPT based fuzzy-logic controller for grid connected residential photovoltaic power system,” in *Proceedings of International Conference in Artificial Intelligence in Renewable Energetic Systems*, Tipaza, Algeria, Dec. 2019, pp. 236-244.
- [20] B. A. Naidu, S. A. Kumar, and D. M. S. S. Narayana, “Fuzzy intelligent controller for the MPPT of a photovoltaic module in comparison with perturb and observe algorithm,” *International Journal of Applied Engineering Research*, vol. 13, pp. 10058-10062, Jan. 2018.
- [21] O. Kececioglu, A. Gani, and M. Sekkeli, “Design and hardware implementation based on hybrid structure for MPPT of PV system using an interval type-2 TSK fuzzy logic controller,” *Energies*, vol. 13, no. 7, pp. 1842-1859, Apr. 2020.
- [22] B. Benlahbib, N. Bouarroudj, S. Mekhilef *et al.*, “A fuzzy logic controller based on maximum power point tracking algorithm for partially shaded PV array-experimental validation,” *Elektronika Ir Elektrotehnika*, vol. 24, pp. 38-44, Aug. 2018.
- [23] H. Suryatmojo, R. Mardiyanto, D. C. Riawan *et al.*, “Design of MPPT based fuzzy logic for solar-powered unmanned aerial vehicle application,” in *Proceedings of International Conference on Engineering, Applied Sciences, and Technology (ICEAST)*, Phuket, Thailand, Aug. 2018, pp. 1-4.
- [24] C. R. Algarin, R. L. Fuentes, and A. O. Castro, “Implementation of a cost-effective fuzzy MPPT controller on the Arduino board,” *International Journal on Smart Sensing and Intelligent Systems*, vol. 11, no. 1, pp. 1-9, Feb. 2018.
- [25] T. Zhu, H. Zhou, H. Wei *et al.*, “Inter-hour direct normal irradiance forecast with multiple data types and time-series,” *Journal of Modern Power Systems and Clean Energy*, vol. 7, no. 5, pp. 1319-1327, Jul. 2019.
- [26] A. Youssefa, M. E. Telbany, and A. Zekry, “Reconfigurable generic FPGA implementation of fuzzy logic controller for MPPT of PV systems,” *Renewable and Sustainable Energy Reviews*, vol. 82, pp. 1313-1319, Feb. 2018.
- [27] E. Kandemir, S. Borekci, and N. S. Cetin, “Comparative analysis of reduced-rule compressed fuzzy logic control and incremental conductance MPPT methods,” *Journal of Electronic Materials*, vol. 47, pp. 4463-4474, Apr. 2018.
- [28] B. K. Naick, K. Chatterjee, and T. Chatterjee, “Fuzzy logic controller based maximum power point tracking technique for different configurations of partially shaded photovoltaic system,” *Archives of Electrical Engineering*, vol. 67, pp. 307-320, Aug. 2018.
- [29] P. Verma, R. Garg, and P. Mahajan, “Asymmetrical interval type-2 fuzzy logic control based MPPT tuning for PV system under partial shading condition,” *ISA Transactions*, vol. 100, pp. 251-263, May 2020.
- [30] M. Eydi and R. Ghazi, “A novel strategy of maximum power point tracking for photovoltaic panels based on fuzzy logic algorithm,” *Advances in Electrical and Electronic Engineering*, vol. 18, no. 1, pp. 1-10, Mar. 2020.
- [31] S. D. Al-Majidi, M. F. Abbod, and H. S. Al-Raweshidy, “A novel maximum power point tracking technique based on fuzzy logic for photovoltaic systems,” *International Journal of Hydrogen Energy*, vol. 43, pp. 14158-14171, Aug. 2018.
- [32] S. Samal, S. K. Sahu, and P. K. Barik, “Extraction of maximum power from a solar PV system using fuzzy controller based MPPT technique,” in *Proceedings of IEEE International Conference on Technologies for Smart-City Energy Security and Power (ICSESP-2018)*, Bhubaneswar, India, Mar. 2018, pp. 1-6.
- [33] E. Kandemir, S. Borekci, and N. S. Cetin, “Conventional and soft-computing based MPPT methods comparisons in direct and indirect modes for single stage PV systems,” *Elektronika Ir Elektrotehnika*, vol. 24, pp. 45-52, Aug. 2018.
- [34] M. Ali, A. Talha, and E. M. Berkouk, “New M5P model tree-based control for doubly fed induction generator in wind energy conversion system,” *Wind Energy*, vol. 23, no. 9, pp. 1831-1845, Jun. 2020.
- [35] J.-C. Kim, J.-C. Kim, and J.-S. Ko, “Optimization design and test bed of fuzzy control rule base for PV system MPPT in micro grid,” *Sustainability*, vol. 12, no. 9, pp. 3763-3787, May 2020.
- [36] S. Blaifi, S. Moulahoum, R. Benkercha *et al.*, “M5P model tree based fast fuzzy maximum power point tracker,” *Solar Energy*, vol. 163, pp. 405-424, Mar. 2018.
- [37] C. H. Basha and C. Rani, “Different conventional and soft computing MPPT techniques for solar PV systems with high step-up boost converters: a comprehensive analysis,” *Energies*, vol. 13, pp. 371-397, Jan. 2020.
- [38] J. M. Lopez-Guede, J. Ramos-Hernanz, N. Altin *et al.*, “Neural modeling of fuzzy controllers for maximum power point tracking in photovoltaic energy systems,” *Journal of Electronic Materials*, vol. 47, pp. 4519-4532, Jun. 2018.
- [39] J. J. Khanam and S. Y. Foo, “Modeling of a photovoltaic array in MATLAB Simulink and maximum power point tracking using neural network,” *Electrical & Electronic Technology Open Access Journal*, vol. 2, no. 2, pp. 40-46, Jul. 2018.
- [40] L. Chen and X. Wang, “An enhanced MPPT Method based on ANN-assisted sequential Monte Carlo and quickest change detection,” *IET Smart Grid*, vol. 2, no. 4, pp. 635-644, Dec. 2019.
- [41] Chtouki, P. Wira, and M. Zazi, “Comparison of several neural network perturb and observe MPPT methods for photovoltaic applications,” in *Proceedings of IEEE International Conference on Industrial Technology (ICIT)*, Lyon, France, Feb. 2018, pp. 909-914.
- [42] A. B. M. S. Bouakkaz, O. Boudebbouz, A. Bouraiou *et al.*, “ANN based MPPT algorithm design using real operating climatic condition,” in *Proceedings of 2nd International Conference on Mathematics and Information Technology (ICMIT)*, Adrar, Algeria, Feb. 2020, pp.

- 159-163.
- [43] C. R. Algarín, S. H. Deimer, and D. R. Leal, "A low-cost maximum power point tracking system based on neural network inverse model controller," *Electronics Journal*, vol. 7, no. 1, pp. 4-20, Jan. 2018.
- [44] R. Divyasharon, R. N. Banu, and D. Devaraj, "Artificial neural network based MPPT with CUK converter topology for PV systems under varying climatic conditions," in *Proceedings of IEEE International Conference on Intelligent Techniques in Control, Optimization and Signal Processing (INCOS)*, Tamilnadu, India, Apr. 2019, pp. 1-6.
- [45] K. Fatima, M. A. Alam, and A. F. Minai, "Optimization of solar energy using ANN techniques," in *Proceedings of 2nd International Conference on Power Energy, Environment and Intelligent Control (PEE-IC)*, Greater Noida, India, Oct. 2019, pp. 174-179.
- [46] S. D. Al-Majidi, M. F. Abbod, and H. S. Al-Rawashidy, "Design of an intelligent MPPT based on ANN using a real photovoltaic system data," in *Proceedings of 54th International Universities Power Engineering Conference (UPEC)*, Bucharest, Romania, Sept. 2019, pp. 1-6.
- [47] S. D. Al-Majidi, M. F. Abbod, H. S. Al-Rawashidy *et al.*, "A particle swarm optimisation-trained feedforward neural network for predicting the maximum power point of a photovoltaic array," *Engineering Applications of Artificial Intelligence*, vol. 92, pp. 103688-103700, Jun. 2020.
- [48] P. N. J. Lakshmi and M. R. Sindhu, "An artificial neural network based MPPT algorithm for solar PV system," in *Proceedings of 2018 4th International Conference on Electrical Energy Systems (ICEES)*, Chennai, India, Feb. 2019, pp. 375-380.
- [49] H. D. Tafti, A. Sangwongwanich, Y. Yang *et al.*, "A general algorithm for flexible active power control of photovoltaic systems," in *Proceedings of IEEE Applied Power Electronics Conference and Exposition (APEC)*, San Antonio, USA, Mar. 2018, pp. 1115-1121.
- [50] Y. Huang, X. Chen, and C. Ye, "A hybrid maximum power point tracking approach for photovoltaic systems under partial shading conditions using a modified genetic algorithm and the firefly algorithm," *International Journal of Photoenergy*, pp. 1-13, May 2018.
- [51] J. Zhang, N. Liu, J. Xu *et al.*, "Novel MPPT method based on large variance GA-RBF," *Journal of Engineering*, vol. 2019, no. 16, pp. 3365-3370, Mar. 2019.
- [52] A. Harrag and S. Messalti, "Adaptive GA-based reconfiguration of photovoltaic array combating partial shading conditions," *Neural Comput & Applic*, vol. 30, pp. 1145-1170, Dec. 2016.
- [53] K. Anoop and M. Nandakumar, "A novel maximum power point tracking method based on particle swarm optimization combined with one cycle control," in *Proceedings of International Conference on Power, Instrumentation, Control and Computing (PICC)*, Thrissur, India, Jan. 2018, pp. 1-6.
- [54] N. Kalaiarasi, S. S. Dash, S. Padmanaban *et al.*, "Maximum power point tracking implementation by dspace controller integrated through z-source inverter using particle swarm optimization technique for photovoltaic applications," *Applied Science*, vol. 8, no. 1, pp. 145-162, Jan. 2018.
- [55] H. Li and D. Yang, "An overall distribution particle swarm optimization MPPT algorithm for photovoltaic system under partial shading," *IEEE Transactions on Industrial Electronics*, vol. 66, no. 1, pp. 265-275, Apr. 2018.
- [56] M. Merchaoui, A. Saklyl, and M. F. Mimouni, "Improved fast particle swarm optimization based PV MPPT," in *Proceedings of the 9th International Renewable Energy Congress (IREC 2018)*, Hammamet, Tunisia, Apr. 2018, pp. 1-6.
- [57] L.-Y. Chang, Y.-N. Chung, K.-H. Chao *et al.*, "Smart global maximum power point tracking controller of photovoltaic module arrays," *Energies*, vol. 11, no. 3, pp. 567-582, Mar. 2018.
- [58] H. M. H. Farh, M. F. Othman, A. M. Eltamaly *et al.*, "Maximum power extraction from a partially shaded PV system using an interleaved boost converter," *Energies*, vol. 11, no. 10, pp. 2543-2560, Sept. 2018.
- [59] L. Guo, Z. Meng, Y. Sun *et al.*, "A modified cat swarm optimization based maximum power point tracking method for photovoltaic system under partially shaded condition," *Energy*, vol. 144, pp. 501-514, Feb. 2018.
- [60] N. Aouchiche, M. Aitcheikh, M. Becherif *et al.*, "AI-based global MPPT for partial shaded grid connected PV plant via MFO approach," *Solar Energy*, vol. 171, pp. 593-603, Sept. 2018.
- [61] B. R. Peng, K. C. Ho, and Y. H. Liu, "A novel and fast MPPT method suitable for both fast changing and partially shaded conditions," *IEEE Transactions on Industrial Electronics*, vol. 65, no. 4, pp. 3240-3251, Aug. 2017.
- [62] J. Ahmed and Z. Salam, "An enhanced adaptive P&O MPPT for fast and efficient tracking under varying environmental conditions," *IEEE Transactions on Sustainable Energy*, vol. 9, no. 3, pp. 1487-1496, Jan. 2018.
- [63] L. Li, G. Lin, M. Tseng *et al.*, "A maximum power point tracking method for PV system with improved gravitational search algorithm," *Applied Soft Computing*, vol. 65, pp. 333-348, Apr. 2018.
- [64] A. Tian, S. Chu, J. Pan *et al.*, "A novel pigeon-inspired optimization based MPPT technique for PV systems," *Processes*, vol. 8, no. 3, pp. 356-378, Mar. 2020.
- [65] N. Priyadarshi, V. K. Ramachandaramurthy, S. P. F. Azam, "An ant colony optimized mppt for standalone hybrid PV-wind power system with single cuk converter," *Energies*, vol. 12, no. 1, pp. 167-189, Jan. 2019.
- [66] T. K. Behera, M. K. Behera, and N. Nayak, "Spider monkey based improve P&O MPPT controller for photovoltaic generation system," in *Proceedings of IEEE International Conference on Technologies for Smart-City Energy Security and Power (ICSESP-2018)*, Bhubaneswar, India, Mar. 2018, pp. 1-6.
- [67] M. Mao, Q. Duan, P. Duan *et al.*, "Comprehensive improvement of artificial fish swarm algorithm for global MPPT in PV system under partial shading conditions," *Transactions of the Institute of Measurement and Control*, vol. 40, pp. 2178-2199, May 2017.
- [68] C. Vimalarani, N. Kamaraj, and B. C. Babu, "Improved method of maximum power point tracking of photovoltaic (PV) array using hybrid intelligent controller," *Optik*, vol. 168, pp. 403-415, Sept. 2018.
- [69] S. Nikolovski, H. R. Baghaee, and D. Mlacić, "ANFIS-based peak power shaving/curtailment in microgrids including PV units and BESSs," *Energies*, vol. 11, no. 11, pp. 2953-2975, Oct. 2018.
- [70] R. Syahputra, R. O. Wiyagi, I. Soesanti *et al.*, "Design of maximum power point tracking based on adaptive neuro-fuzzy system for solar array system," *Journal of Theoretical and Applied Information Technology*, vol. 96, pp. 4481-4490, Jul. 2018.
- [71] A. A. Aldair, A. A. Obed, and A. F. Halihal, "Design and implementation of ANFIS-reference model controller based MPPT using FPGA for photovoltaic system," *Renewable and Sustainable Energy Reviews*, vol. 82, pp. 2202-2217, Feb. 2018.
- [72] I. Abadi, C. Imron, R. D. Noriyati *et al.*, "Implementation of maximum power point tracking (MPPT) technique on solar tracking system based on adaptive neuro fuzzy inference system (ANFIS)," *E3S Web of Conferences*, vol. 43, pp. 1-8, Jun. 2018.
- [73] A. Ali, A. N. Hasan, "Optimization of PV Model using fuzzy- neural network for DC-DC converter systems," in *Proceedings of 9th International Renewable Energy Congress (IREC)*, Hammamet, Tunisia, Mar. 2018, pp. 1-6.
- [74] S. Duman, N. Yorukeren, and I. H. Altas, "A novel MPPT algorithm based on optimized artificial neural network by using FPSOGSA for standalone photovoltaic energy systems," *Neural Computation & Application*, vol. 29, pp. 257-278, Jul. 2016.
- [75] M. E. Başoğlu and B. Çakır, "Hybrid global maximum power point tracking approach for photovoltaic power optimisers," *IET Renewable Power Generation*, vol. 12, no. 8, pp. 875-882, Jun. 2018.
- [76] J. Macaulay and Z. Zhou, "A fuzzy logical-based variable step size P&O MPPT algorithm for photovoltaic system," *Energies*, vol. 11, no. 6, pp. 1340-1354, May 2018.
- [77] Z. Wang, X. Zhang, B. Hu *et al.*, "Control strategy of grid-connected photovoltaic generation system based on GMPPT method," *IOP Conference Series: Earth and Environmental Science*, vol. 121, no. 4, pp. 1-9, Feb. 2018.
- [78] A. M. Farayola, A. N. Hasan, and A. Ali, "Efficient photovoltaic mppt system using coarse Gaussian support vector machine and artificial neural network techniques," *International Journal of Innovative Computing, Information and Control*, vol. 14, pp. 323-339, Feb. 2018.
- [79] A. M. Farayola, A. N. Hasan, and A. Ali, "Optimization of PV systems using data mining and regression learner MPPT techniques," *Indonesian Journal of Electrical Engineering and Computer Science*, vol. 10, no. 3, pp. 1080-1089, Mar. 2018.
- [80] M. Lasheena and M. Abdel-Salam, "Maximum power point tracking using hill climbing and ANFIS techniques for PV applications: a review and a novel hybrid approach," *Energy Conversion and Management*, vol. 171, pp. 1002-1019, Sept. 2018.
- [81] Y. Du, K. Yan, Z. Ren *et al.*, "Designing localized MPPT for PV systems using fuzzy-weighted extreme learning machine," *Energies*, vol. 11, pp. 2615-2624, Oct. 2018.
- [82] M. Dehghani, M. Taghipour, G. B. Gharehpetian *et al.*, "Optimized fuzzy controller for MPPT of grid-connected PV systems in rapidly changing atmospheric conditions," *Journal of Modern Power Systems and Clean Energy*. doi: 10.35833/MPCE.2019.000086
- [83] N. Priyadarshi, S. Padmanaban, J. B. Holm-Nielsen *et al.*, "An experi-



- mental estimation of hybrid ANFIS-PSO-based MPPT for PV grid integration under fluctuating sun irradiance,” *IEEE Systems Journal*, vol. 14, no. 1, pp. 1218-1229, Nov. 2019 .
- [84] B. Talbi, F. Krim, T. Rekioua *et al.*, “A high-performance control scheme for photovoltaic pumping system under sudden irradiance and load changes,” *Solar Energy*, vol. 159, pp. 353-368, Jan. 2018.
- [85] F. Keyrouz, “Enhanced Bayesian based MPPT controller for PV systems,” *IEEE Power and Energy Technology Systems Journal*, vol. 5, no. 1, pp. 11-17, Mar. 2018.
- [86] M. K. Behera, I. Majumder, and N. Nayak, “Solar photovoltaic power forecasting using optimized modified extreme learning machine technique,” *Engineering Science and Technology*, vol. 21, pp. 428-438, Jun. 2018.
- [87] K. S. Tey, S. Mekhilef, M. Seyedmahmoudian *et al.*, “Improved differential evolution-based MPPT algorithm using SEPIC for PV systems under partial shading conditions and load variation,” *IEEE Transactions on Industrial Informatics*, vol. 14, no. 10, pp. 4322-4333, Jan. 2018.
- [88] T. Pei, X. Hao, and Q. Gu, “A novel global maximum power point tracking strategy based on modified flower pollination algorithm for photovoltaic systems under non-uniform irradiation and temperature conditions,” *Energies*, vol. 11, pp. 2708-2723, Oct. 2018.
- [89] A. K. Podder, N. K. Roy, and H. R. Pota, “MPPT methods for solar PV systems: a critical review based on tracking nature,” *IET Renewable Power Generation*, vol. 13, no. 10, pp. 1615-1632, Jul. 2019.
- [90] Z. Bi, J. Ma, K. Wang *et al.*, “Identification of partial shading conditions for photovoltaic strings,” *IEEE Access*, vol. 8, pp. 75491-75502, Apr. 2020.
- [91] E. M. Vicente, P. d. S. Vicente, R. L. Moreno *et al.*, “High-efficiency MPPT method based on irradiance and temperature measurements,” *IET Renewable Power Generation*, vol. 14, no. 6, pp. 986-995, Apr. 2020.
- [92] A. Sfirat, A. Gontean, and S. Bularka, “A new method for MPPT algorithm implementation and testing, suitable for photovoltaic cells,” *Advances in Electrical and Computer Engineering*, vol. 18, pp. 53-60, Aug. 2018.
- [93] A. Kapić, Ž. Zečević, and B. Krstajić, “An efficient MPPT algorithm for PV modules under partial shading and sudden change in irradiance,” in *Proceedings of 23rd International Scientific-Professional Conference on Information Technology (IT)*, Zabljak, Montenegro, Feb. 2018, pp. 1-4.
- [94] S. Krishnan, S. Kinattingal, S. P. Simon *et al.*, “MPPT in PV systems using ant colony optimisation with dwindling population,” *IET Renewable Power Generation*, vol. 14, no. 7, pp. 1105-1112, May 2020.
- [95] H. Islam, S. Mekhilef, N. B. M. Shah *et al.*, “Performance evaluation of maximum power point tracking approaches and photovoltaic systems,” *Energies*, vol. 11, no. 2, p. 365-388, Feb. 2018.
- [96] R. Iftikhar, I. Ahmad, M. Arsalan *et al.*, “MPPT for photovoltaic system using nonlinear controller,” *International Journal of Photoenergy*, vol. 2018, pp. 1-16, Apr. 2018.
- [97] K. Y. Yap, C. R. Sarimuthu, and J. M.-Y. Lim, “Virtual inertia-based inverters for mitigating frequency instability in grid-connected renewable energy system: a review,” *Applied Science*, vol. 9, no. 24, pp. 5300-5328, Dec. 2019.
- [98] A. P. Azad, M. Padmanaban, and V. Arya, “A data lens into MPPT efficiency and PV power prediction,” in *Proceedings of IEEE Power & Energy Society Innovative Smart Grid Technologies Conference (ISGT)*, Washington DC, USA, Feb. 2018, pp. 1-5.
- [99] A. M. Farayola, A. N. Hasan, and A. Ali, “Use of MPPT techniques to reduce the energy pay-back time in PV systems,” in *Proceedings of the 9th International Renewable Energy Congress (IREC 2018)*, Hammamet, Tunisia, Mar. 2018, pp. 1-6.
- [100] S. Obukhov, A. Ibrahim, A. A. Z. Diab *et al.*, “Optimal performance of dynamic particle swarm optimization based maximum power trackers for stand-alone PV system under partial shading conditions,” *IEEE Access*, vol. 8, pp. 20770-20785, Jan. 2020.
- [101] K. Y. Yap, C. R. Sarimuthu, and J. M.-Y. Lim, “Grid integration of solar photovoltaic system using machine learning-based virtual inertia synthesis in synchronverter,” *IEEE Access*, vol. 8, pp. 49961-49976, Mar. 2020.
- [102] H. M. Somarin and R. Parvari, “Micro-grid stabilizer design using sliding mode controller,” *International Journal of Electrical Power & Energy Systems*, vol. 116, pp. 105519-105526, Mar. 2020.

**Kah Yung Yap** received the B.Eng. degree (Hons.) in electrical and electronic engineering from University College Sedaya International (UCSI), Cheras, Wilayah Persekutuan Kuala Lumpur, Malaysia. He is currently pursuing the Ph. D. degree in electrical and computer systems engineering (ECSE) at Monash University, Subang Jaya, Selangor, Malaysia under Graduate Research Merit Full Scholarship. He is a Graduate Engineer of the Board of Engineers Malaysia (BEM) and a Graduate Member of the Institution of Engineers Malaysia (IEM). He was awarded the 2017 IEM Gold Award Medal for the Best Engineering Student. He is also a graduate student member of The Institute of Electrical and Electronics Engineers (IEEE), a society member in IEEE Power & Energy Society (PES) and a member of The Institution of Engineering and Technology (MIET). His current research interests include machine learning based synchronverters, grid-connected solar photovoltaic systems, and power quality improvement.

**Charles R. Sarimuthu** received the B.Eng. and M.Eng. degrees in electrical engineering from the University of Malaya, Wilayah Persekutuan Kuala Lumpur, Malaysia, in 2006 and 2010, respectively, and the Ph.D. degree in electrical power engineering from National Energy University, Kajang, Malaysia, in 2019. He is a member of the Institution of Engineers Malaysia (IEM) and a Registered Engineer of the Board of Engineers Malaysia (BEM). In 2018, he joined as a Lecturer with the Department of Electrical and Computer Systems Engineering, School of Engineering, Monash University, Subang Jaya, Malaysia. His research interests include power system, power quality, renewable energy, and smart grid.

**Joanne Mun-Yee Lim** received the B.E. degree (Hons.) from Monash University, Subang Jaya, Malaysia, in 2008, the M.E. degree from the University of Malaya, Wilayah Persekutuan Kuala Lumpur, Malaysia, in 2011, and the Ph.D. degree in engineering from Multimedia University, Cyberjaya, Malaysia, in 2016. She received an Outstanding Dissertation Award from the IEEE Malaysia ComSoc/Vehicular Technology Society Joint Chapter for her Ph.D. work. She is also a member of The Institution of Engineers Malaysia and a Professional Engineer of the Board of Engineers Malaysia. She is currently a Lecturer with Monash University. Her research interests include vehicular Ad-hoc networks, mobile IPv6-based network, unmanned aerial vehicle, artificial intelligence, control system, optimization scheme, robotic design, and renewable energy application.